

JARVIS Model SHC 140, 165, 165B, 165G, 165GT & 205 Hydraulic Circular Saw

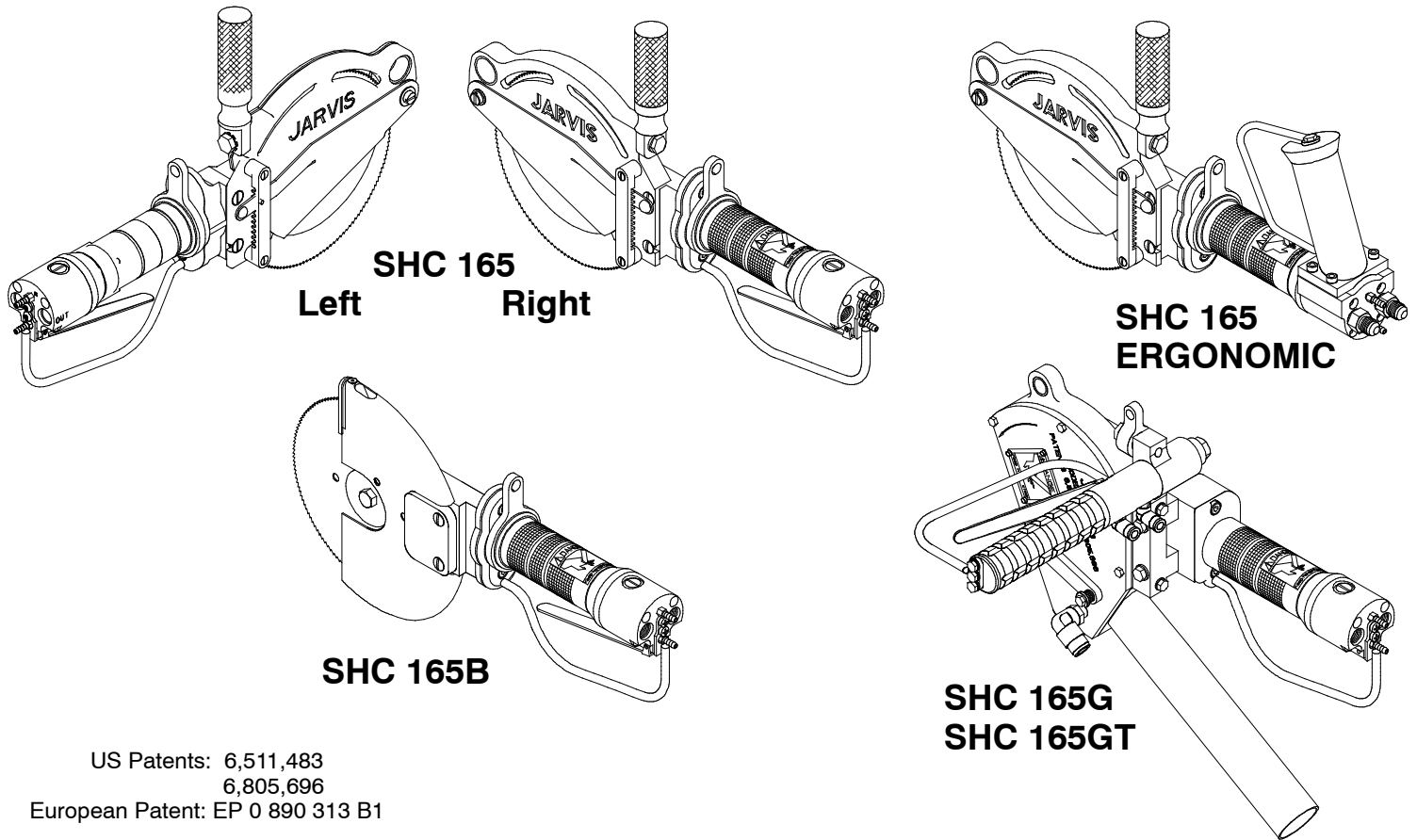

US Patents: 6,511,483
6,805,696
European Patent: EP 0 890 313 B1

EQUIPMENT SELECTION Ordering No.	TABLE OF CONTENTS Page
Model SHC 140	
Model SHC 140 Ergonomic	<ul style="list-style-type: none"> • Safety Messages to Employer and Safety Director 2
Model SHC 140 Left Handed	<ul style="list-style-type: none"> • Safety Messages to Operators, Maintenance and Cleanup Personnel 3
Model SHC 165 Standard	<ul style="list-style-type: none"> • Parts Diagram and List 4
Model SHC 165 Ergonomic	<ul style="list-style-type: none"> • Installation Diagram 12
Model SHC 165 Left Handed	<ul style="list-style-type: none"> • Specifications 14
Model SHC 165B Brisket	<ul style="list-style-type: none"> • Installation Instructions 14
Model SHC 165G (16mm)	<ul style="list-style-type: none"> • Operation Instructions 15
Model SHC 165G (13mm)	<ul style="list-style-type: none"> • Maintenance Instructions 16
Model SHC 165GT (7 Blades)	
Model SHC 205	
Model SHC 205, Left Handed	
Hydr. Power Unit, Single Trigger, 575V/60Hz	
Hydr. Power Unit, Single Trigger, 460V/60Hz	
Hydr. Power Unit, Single Trigger, 440-220V/50Hz	
Hydr. Power Unit, Dual Trigger, 460V/60Hz	
Hydr. Power Unit, Dual Trigger, 440-220V/50Hz .	
Balancer SHC 140, 165, 165B and 205	
Balancer SHC 165G and 165GT	
Tool Kit	

JARVIS®

6207016:.....b

PRODUCTS CORPORATION

33 ANDERSON ROAD, MIDDLETOWN, CONNECTICUT 06457-4926
 UNITED STATES OF AMERICA E-MAIL. sales@jarvisproducts.com
 TEL. 860-347-7271 FAX. 860-347-6978 WWW. jarvisproducts.com



SAFETY MESSAGES TO EMPLOYER AND SAFETY DIRECTOR

AVOID INJURY

1. **Ensure** that all employees who use this tool are trained in the proper use of this tool and are aware of the dangers that may arise if they do not follow the procedures outlined in this brochure.
2. **Enclosed** are four (4) copies of “**NOTICE TO OPERATORS, MAINTENANCE AND CLEANUP PERSONNEL.**” Post one copy on the employees’ bulletin board; give one copy to operator(s); give one copy to the maintenance foreman; and give one copy to the sub-contract cleanup / internal cleanup foreman. *Additional copies will be provided upon request.*
3. The tool is designed and intended to be powerful. This fact should be obvious to your employees, but you must emphasize it to them.
4. **Ensure** that employees wear eye protection in accordance with OSHA’s eye and face protection requirements 29 CFR 1910.133 while operating the tool.
5. **Ensure** that proper procedures are established in accordance with OSHA’s lockout/tagout procedures 29 CFR 1910.147 to prevent accidental startup or release of stored energy.
6. **Remove** and **repair** any tool that malfunctions. **All** personnel must be instructed to remove any malfunctioning equipment.
7. **Never** make modifications or alterations to the tool. *Replace any missing or illegible labels.*
8. **Follow** our installation and maintenance instructions for proper installation and care of the tool.
9. **Avoid** injury. Do not permit the tool to be misused.
10. **If you resell or distribute** a Jarvis product, you must provide the purchaser with the appropriate safety sheets and tool brochure. *Additional copies of safety sheets and tool brochures will be provided upon request.*



**SAFETY MESSAGES TO OPERATORS, MAINTENANCE AND CLEANUP
PERSONNEL**

***REMOVE ANY MALFUNCTIONING TOOL FROM SERVICE
REPORT ANY PROBLEMS TO YOUR SUPERVISOR***

1. **Disconnect** all hydraulic and air hoses and shut the power off in accordance with OSHA's lockout/tagout procedures (29 CFR 1910.147) before making any blade changes.
2. **Disconnect** all hydraulic and air hoses and shut the power off OSHA's lockout/tagout procedures (29 CFR 1910.147) before making any repair or performing any maintenance to the tool.
3. **Disconnect** all hydraulic and air hoses and shut the power off - or have the all hydraulic and air hoses disconnected and the power shut off - in accordance with OSHA's lockout/tagout procedures (29 CFR 1910.147) before performing any cleanup.
4. **Disconnect** all hydraulic and air hoses when the tool is not in use.
5. **Always** wear eye protection in accordance with OSHA's eye and face protection requirements (29 CFR 1910.133) while operating the tool.
6. **Never** put fingers, hands or other parts of the body on the cutting edge or within the cutting path of the tool when it is connected to a power supply.
7. **Always** use both hands when starting and operating the tool to avoid the risk of possible "kick back" or "recoil". **Continue** holding the tool with both hands until the saw blade comes to a complete stop.
8. **Test** the tool prior to use daily. *For single trigger tools:* **Depress** the trigger and the tool should start. **Release** the trigger and the tool should stop. *For dual trigger tools:* **Depress** one trigger, then pause one second and depress the other trigger and the tool should not start. **Repeat** this procedure reversing the triggers. **Depress both** triggers simultaneously and the tool should start. With the tool running, **release one** trigger and the tool should stop. **Continue** holding the depressed trigger and then depress the other trigger. The tool should not start. Repeat this procedure holding the other trigger. *If the tool malfunctions, remove it from service and report or repair it immediately.*
9. **Clean up** any spilled or leaked hydraulic fluid.
10. **Replace** any worn or leaking hydraulic hoses or fittings.
11. **Never** depress the trigger(s) unless you want to use or test the tool.
12. **Never** make modifications or alterations to the tool. *Replace any missing or illegible labels.*

Figure A
SHC-140, 165 and 165B

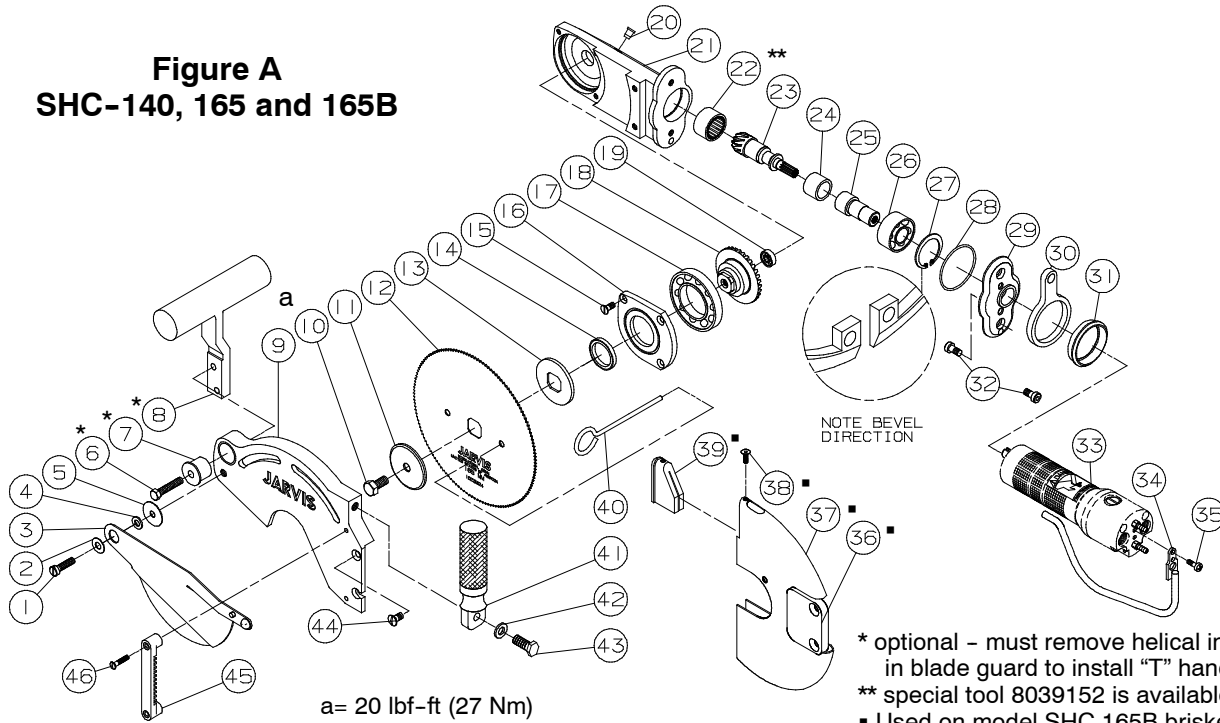

* optional - must remove helical insert in blade guard to install "T" handle.
 ** special tool 8039152 is available
 ■ Used on model SHC 165B brisket saw

ITEM	PART NO.	PART NAME	QTY
1	1055905	Cheese Head Screw	1
2	1004020	Washer	1
3	3025010	Depth Gage Assy, RH 165	1
	3025012	Depth Gage Assy, LH 165	
	3025015	Depth Gage Assy, RH 140	
	3025016	Depth Gage Assy, LH 140	
4	1004001	Washer	1
5	1004021	Washer	1
6	1055954*	Hex Head Screw	2
7	1036130*	Auxiliary Handle Bushing	1
8	1019197*	Auxiliary Handle, RH	1
	1019198*	Auxiliary Handle, LH	
9	1024154	Blade Guard, RH 165	1
	1024174	Blade Guard, LH 165	
	1024190	Blade Guard, RH 140	
	1024192	Blade Guard, LH 140	
10	1054140	Blade Retaining Screw, RH	1
	1054148	Blade Retaining Screw, LH	
11	1004292	Blade Retaining Washer	1
12	1023324	Blade, 140 Teeth (165mm)	1
	1023362	Blade, 120 Teeth (140mm)	
	1023308	Blade, 60 Teeth (165mm)	
	1023363	Blade, 60 Teeth (140mm)	
13	1004293	Slinger	1
14	1035474	Oil Seal	1
15	1055899	Flat Head Screw	3
16	1002355	Gear Housing Cover, RH	1
	1002373	Gear Housing Cover, LH	
17	1021372	Ball Bearing	1
18	1026171	Crown Gear, RH	1
	1026184	Crown Gear, LH	
19	1021081	Ball Bearing	1
20	1038006	Grease Fitting	1
21	3016301	Gear Housing, RH	1
	3016320	Gear Housing, LH	
		with items 20 and 22	
	3016304	Housing & Gear Assy, RH	
	3016319	Housing & Gear Assy, LH	
		(items 10, 11 and 13-27)	

ITEM	PART NO.	PART NAME	QTY
22	1021373	Needle Bearing	1
23	1026170	Pinion Gear, RH	1
	1026183	Pinion Gear, LH	
24	1021374	Bearing Race	1
25	1011300	Coupling	1
26	1021155	Ball Bearing	1
27	1013232	Internal Retaining Ring	1
28	1035164	O-ring	1
29	1032420	Adapter Plate, RH	1
	1032453	Adapter Plate, LH	
30	1042395	Hanger Bracket	1
31	1009153	Hanger Sleeve	1
32	1055742	Socket Head Cap Screw	4
33	3008172	Hydraulic Motor Assy, RH	1
	3008189	Hydraulic Motor Assy, LH	
		(item 152, 157-160, 164-179)	
34	1024155	Trigger Guard	1
35	1055725	Pan Head Screw	2
36	1032479■	Guard Mounting Plate	1
37	1024023■	Blade Guard (Brisket)	1
38	1055918■	Flat Head Screw	1
39	1058153■	Blade Guide (Brisket)	1
40	8039099	Blade Locking Pin	1
41	1019001	Straight Handle	1
42	1004003	Lock Washer	1
43	1055802	Hex Head Screw	1
44	1055835	Flat Head Screw	2
45	1033012	Depth Gage Index	1
46	1055901	Oval Head Screw	2
	3024035	Guard & Gage Assy, RH 165	
	3024037	Guard & Gage Assy, LH 165	
	3024039	Guard & Gage Assy, RH 140	
	3024040	Guard & Gage Assy, LH 140	
		(items 1-5, 9, 45 and 46)	
	3024041	Guard Assembly (Brisket)	
		(items 36-39)	
	3019218*	T-Handle Kit, RH (items 6-8)	
	3019217*	T-Handle Kit, LH (items 6-8)	

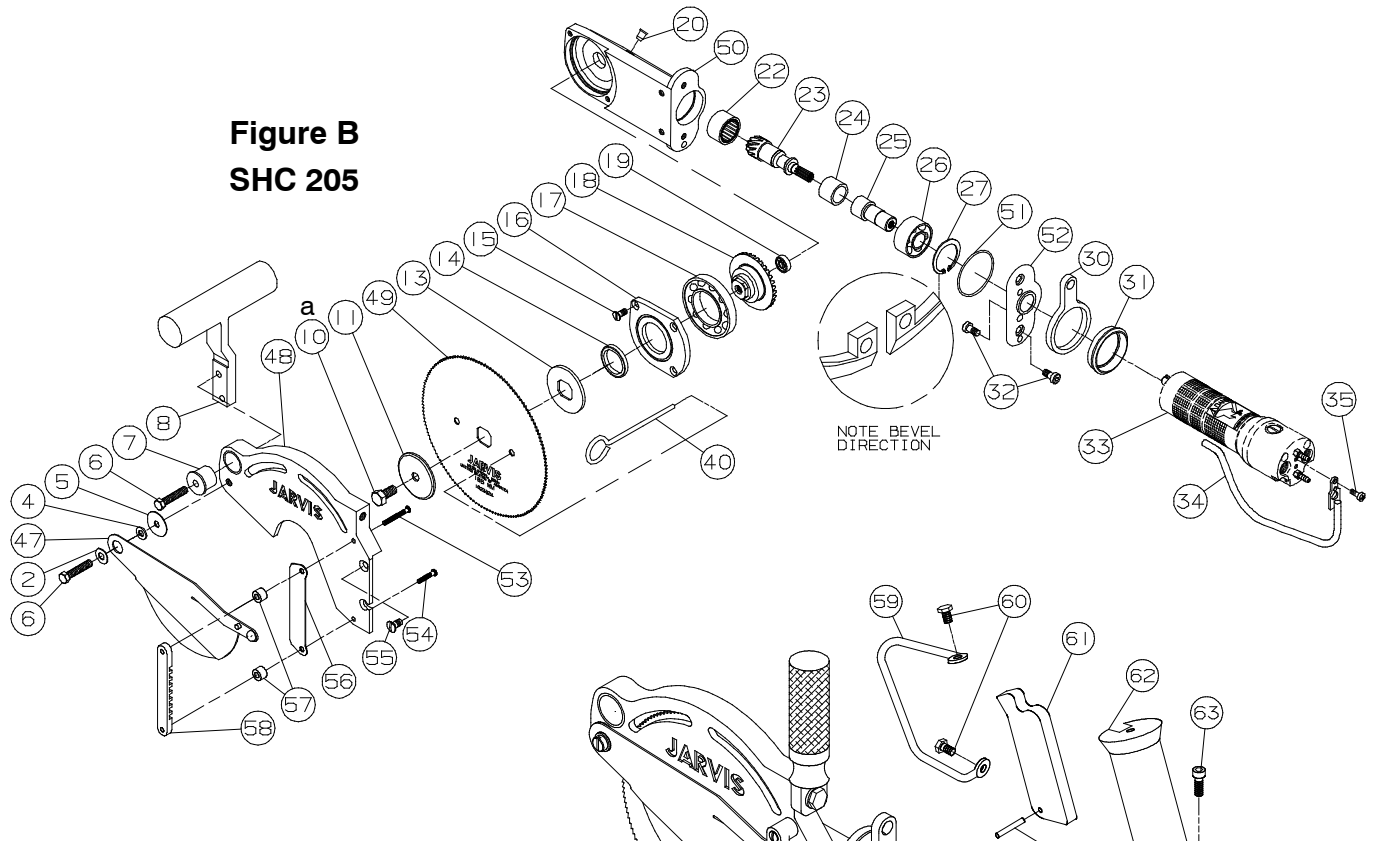

a= 20 lbf-ft (27 Nm)

ITEM	PART NO.	PART NAME	QTY
47	3025017	Depth Gage Assy, RH	1
	3025021	Depth Gage Assy, LH	1
48	1024286	Blade Guard, RH	1
	1024287	Blade Guard, LH	1
49	1023593	Blade, 76 Teeth (205 mm)	1
50	3016500	Right Hand Gear Housing	1
	3016501	Left Hand Gear Housing (with items 20 and 22)	1
51	1035005	O-ring	1
52	1032678	Adapter Plate, RH	1
	1032679	Adapter Plate, LH	1
53	1073023	Flat Head Phillips Screw	1
54	1073024	Flat Head Phillips Screw	1
55	1073215	Flat Head Slotted Screw	2
56	1032494	Rub Plate	1
57	1029028	Spacer	2
58	1033017	Depth Gage Index	1
59	1024149	Trigger Guard	1
60	1055755	Hex Head Screw	2
61	1018131	Trigger Lever	1
62	1019224	Handle	1
63	1055157	Socket Head Cap Screw	4
64	1010286	Dowel Pin	1
65	1061966	Hydraulic Manifold w/item 73	1
66	1051082	Tube Connector	2
67	1073120	Socket Head Cap Screw	4
68	1051081	Plug	1
69	1035245	O-ring	1
70	1014086	Spring	1
71	1039034	Plunger Valve with item 72	1

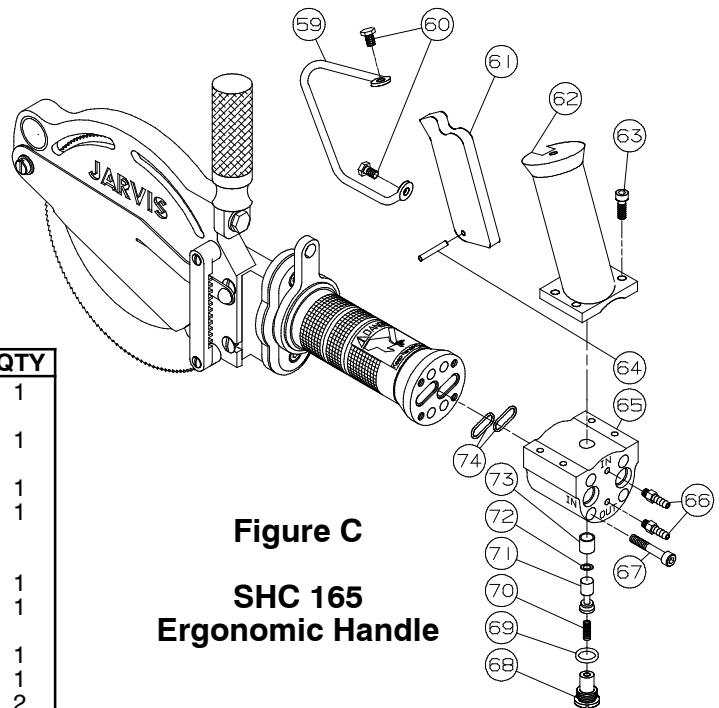

Figure C
SHC 165
Ergonomic Handle

ITEM	PART NO.	PART NAME	QTY
72	1035279	O-ring	1
73	1021294	Bushing	1
74	1035479	O-ring	4
	3019266	Ergonomic Handle Kit (items 59-73 and 183)	
	3016530	Housing & Gear Assy, 205 RH	
	3016531	Housing & Gear Assy, 205 LH (items 10, 11, 13-20, 22-27 and 50)	
	3024067	Guard & Gage Assy SHC205RH	
	3024068	Guard & Gage Assy SHC205LH (items 2, 4, 5, 7, 47, 48, 53, 54, 56-58)	

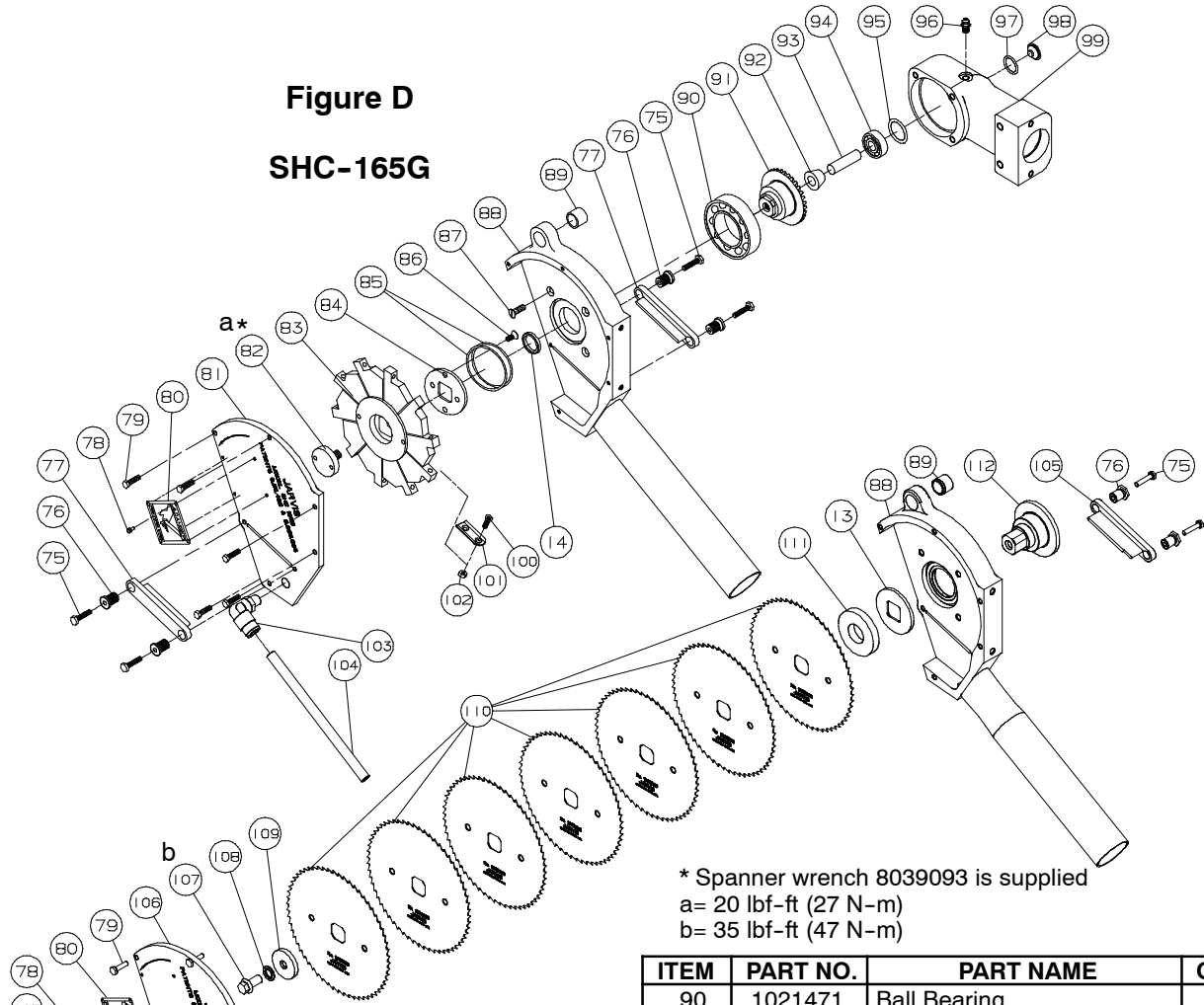

Figure D
SHC-165G

Figure E
SHC-165GT

* Spanner wrench 8039093 is supplied
a= 20 lbf-ft (27 N-m)
b= 35 lbf-ft (47 N-m)

ITEM	PART NO.	PART NAME	QTY
75	1055979	Hex Head Screw	4
76	1027078	Adjustable Stud	4
77	1023536	Blade Scraper	2
	3023190	Blade Scraper Kit (incls. 2 items 75 and 76, 1 item 77)	2
78	1055616	Cheese Head Screw	4
79	1055230	Hex Head Screw	5
80	1017081	Danger Label	1
81	1002519	Blade Guard Cover with items 79 and 80	1
82	1054194	Blade Retaining Screw	1
83	1023550	Blade Insert Holder, 16 mm	1
	1023549	Blade Insert Holder, 13 mm	1
84	1004421	Slinger	1
85	1035697	Seal	2
86	1055390	Flat Head Screw	4
87	1055395	Oval Head Screw	3
88	1024274	Blade Guard with item 89	1
89	1036206	Hanger Bushing	1

ITEM	PART NO.	PART NAME	QTY
90	1021471	Ball Bearing	1
91	1026251	Crown Gear with item 93	1
92	1029420	Spacer	1
93	1010522	Dowel Pin	1
94	1021470	Ball Bearing	1
95	1014194	Wave Spring	1
96	1038027	Grease Fitting	1
97	1035064	O-ring	1
98	1054097	Plug with item 97	1
99	3016487	Gear Hd w/items 22, 96-98	1
100	1055377	Flat Head Screw	10
101	1023545	Blade Insert, 16 mm	10
	1023535	Blade Insert, 13 mm	10
	3023189	Blade Insert 10 pack, 16mm	
	3023193	Blade Insert 10 pack, 13mm	
102	1007254	Lock Nut	10
103	1051118	Connector Elbow	1
104	1071480	Plastic Tubing, 15 ft	1
105	1023639	Blade Scraper	2
106	1002624	Cover	1
107	1073138	Blade Retaining Screw,	1
108	1004486	Internal Tooth Lock Washer	1
109	1004487	Blade Retaining Washer	1
110	1023363	Blade, 60 Teeth	7
111	1029492	Blade Stack Spacer	1
112	1026294	Crown Gear	1
	3059032	Vacuum Hose Assy, 10 ft	1
	3024066	Guard Assembly (items 14, 78-81, 88 and 89)	

Figure F

SHC-165G
SHC-165GT

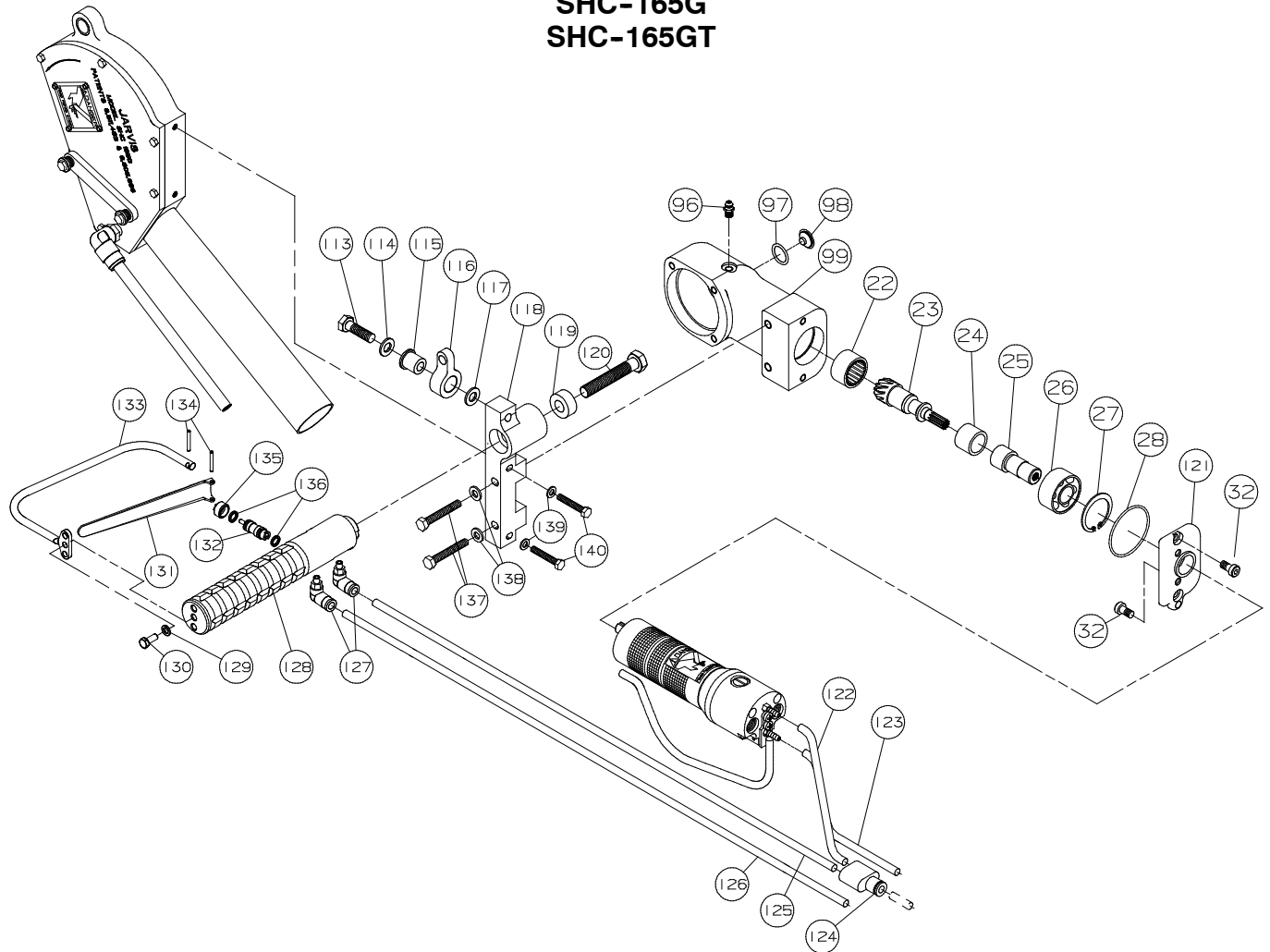

ITEM	PART NO.	PART NAME	QTY
113	1055753	Hex Head Screw	1
114	1004304	Washer	1
115	1036334	Flanged Bushing	1
116	1071073	Hanger	1
117	1004431	Washer	1
118	1042559	Guard and Hanger Bracket	1
119	1029450	Spacer	1
120	1055132	Hex Head Screw	1
121	1032645	Adapter Plate	1
122	1061670	Blue Tubing, 2 feet	1
123	1061457	Yellow Tubing 6 feet	1
124	1051313	"Y" Fitting	1
125	1071150	Blue Tubing, 4 feet	1
126	1071226	Yellow Tubing, 8 feet	1
127	1051263	Elbow Fitting	2
128	1019256	Front Handle	1

ITEM	PART NO.	PART NAME	QTY
129	1004230	Split Lock Washer	3
130	1055755	Hex Head Screw	3
131	1018132	Trigger Lever	1
132	1022211	3-Way Valve with item 136	1
133	1024191	Trigger Guard	1
134	1010577	Dowel Pin	2
135	1054153	Threaded Plug	1
136	1035012	O-ring	2
137	1055404	Hex Head Screw	2
138	1004262	Washer	2
139	1004361	Washer	2
140	1055055	Hex Head Screw	2
	3019306	Handle Assembly (items 119, 120, and 127-136)	
	3019331	Dual Trigger ATD Kit (items 113-120, 122-135)	

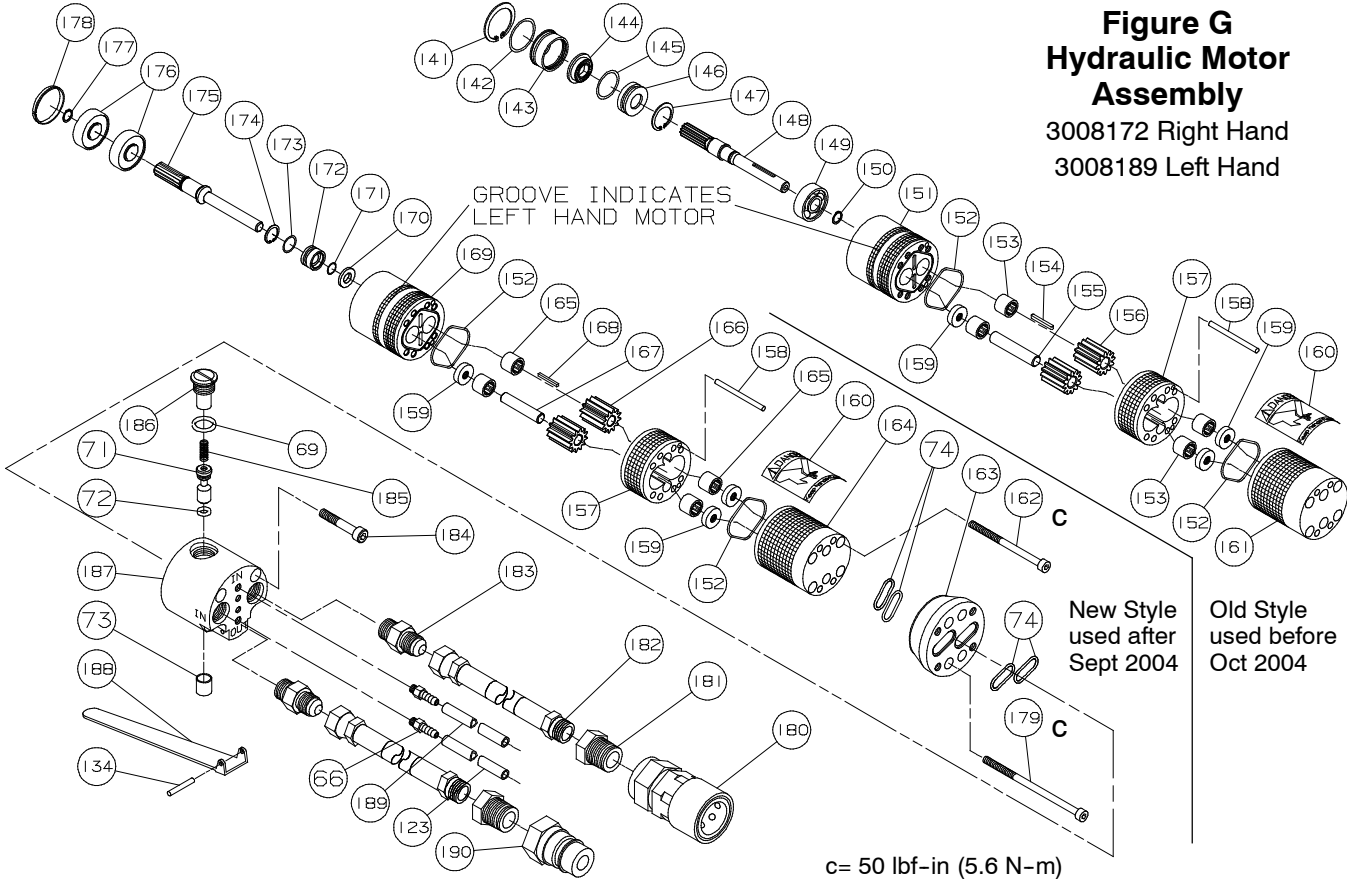

Figure G
Hydraulic Motor
Assembly

3008172 Right Hand
3008189 Left Hand

ITEM	PART NO.	PART NAME	QTY
141	1013233	Internal Retaining Ring	1
142	1035571	O-ring	1
143	1016570	Seal Housing	1
144	1035570	Oil Seal	1
145	1035308	O-ring	1
146	1061807	Seal Gland	1
147	1013180	Internal Retaining Ring	1
148	1020260	Drive Shaft	1
149	1021351	Ball Bearing	1
150	1013217	External Retaining Ring	1
151	3016302	Motor Front Hsg. Assy, RH	1
	3016321	Motor Front Hsg. Assy, LH (with items 153 and 159)	1
152	1035478	O-ring	2
153	1021362	Needle Bearing	4
154	1030065	Key	1
155	1020261	Idler Shaft	1
156	1026172	Gear	2
157	1032421	Motor Center Plate	1
158	1010390	Dowel Pin	2
159	1004347	Extraction Washer	3
160	1017083	Danger Label	1
161	3016303	Motor Rear Housing Assy (with items 153 and 159)	1
162	1055902	Socket Head Cap Screw	4
163	1032422	Manifold Plate	1
164	3016515	Motor Rear Hsg Assy, RH	1
	3016521	Motor Rear Hsg Assy, LH (with items 159 and 165)	1
165	1021498	Needle Bearing	4
166	1026279	Gear	2
167	1020405	Idler Shaft	1

ITEM	PART NO.	PART NAME	QTY
168	1030099	Key	1
169	3016516	Motor Front Hsg Assy, RH	1
	3016517	Motor Front Hsg Assy, LH (with items 159 and 165)	1
170	1004461	Seal Retaining Washer	1
171	1035689	Seal	1
172	1016707	Seal Housing	1
173	1035400	O-ring	1
174	1013197	Internal Retaining Ring	1
175	1020401	Drive Shaft	1
176	1021499	Ball Bearing	2
177	1013116	External Retaining Ring	1
178	1013317	Bearing Retaining Ring	1
179	1055903	Socket Head Cap Screw	4
180	1011087	Quick Connect Socket	1
181	1050602	Reducer Bushing	2
182	3059009	Hose Assy, 6 ft	2
183	1050230	Male Connector	2
184	1055904	Socket Head Cap Screw	4
185	1014086	Spring	1
186	1051081	Plug	1
187	1061636	Hydraulic Manifold with item 73	1
188	1018132	Trigger Lever	1
189	1061456	Blue Tubing, 6 feet	1
190	1011086	Quick Connect Plug	1
	3022055	Air Switch Valve Assy (items 66, 69, 71-73, 134, 183 and 185-188)	
	3035058	Hyd Motor Seal Kit (old) (items 142-147 and 152)	
	3035093	Hyd Motor Seal Kit (new)(items 152, 171-174 and 178)	

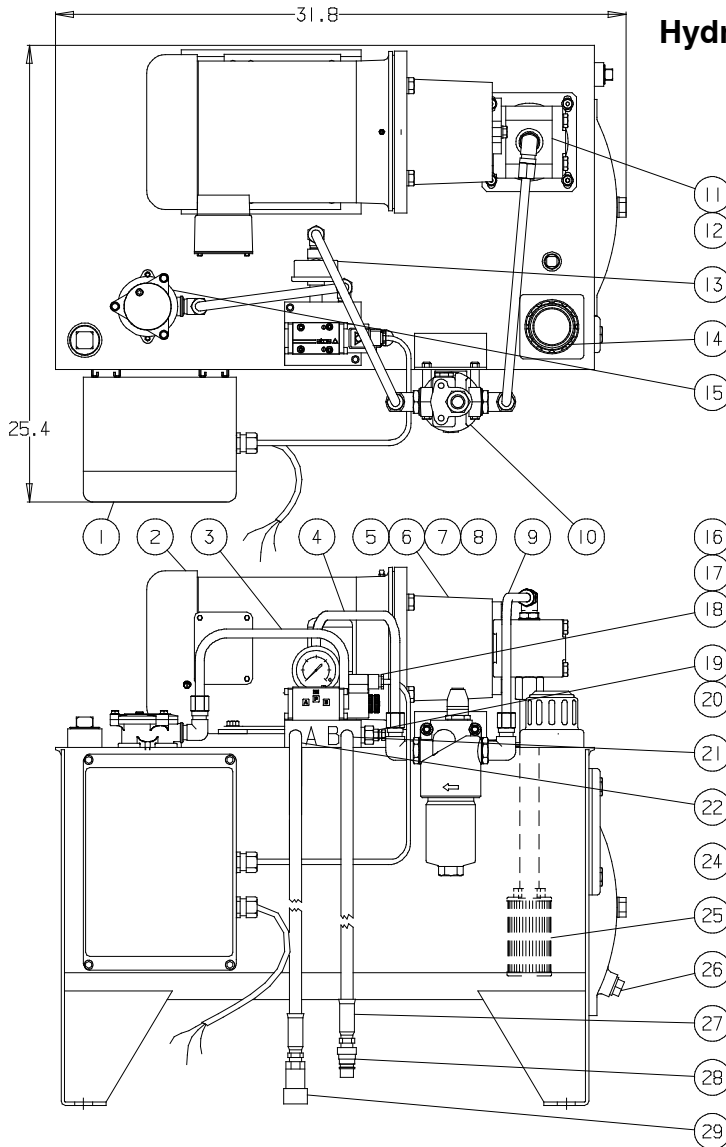
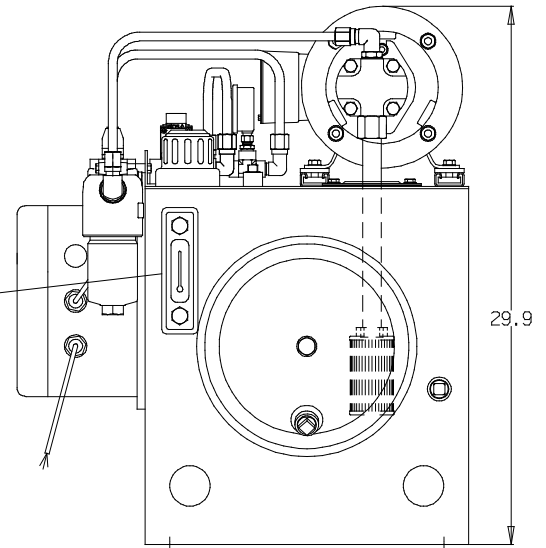
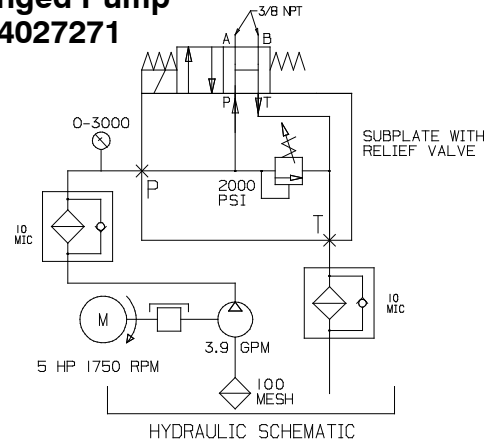
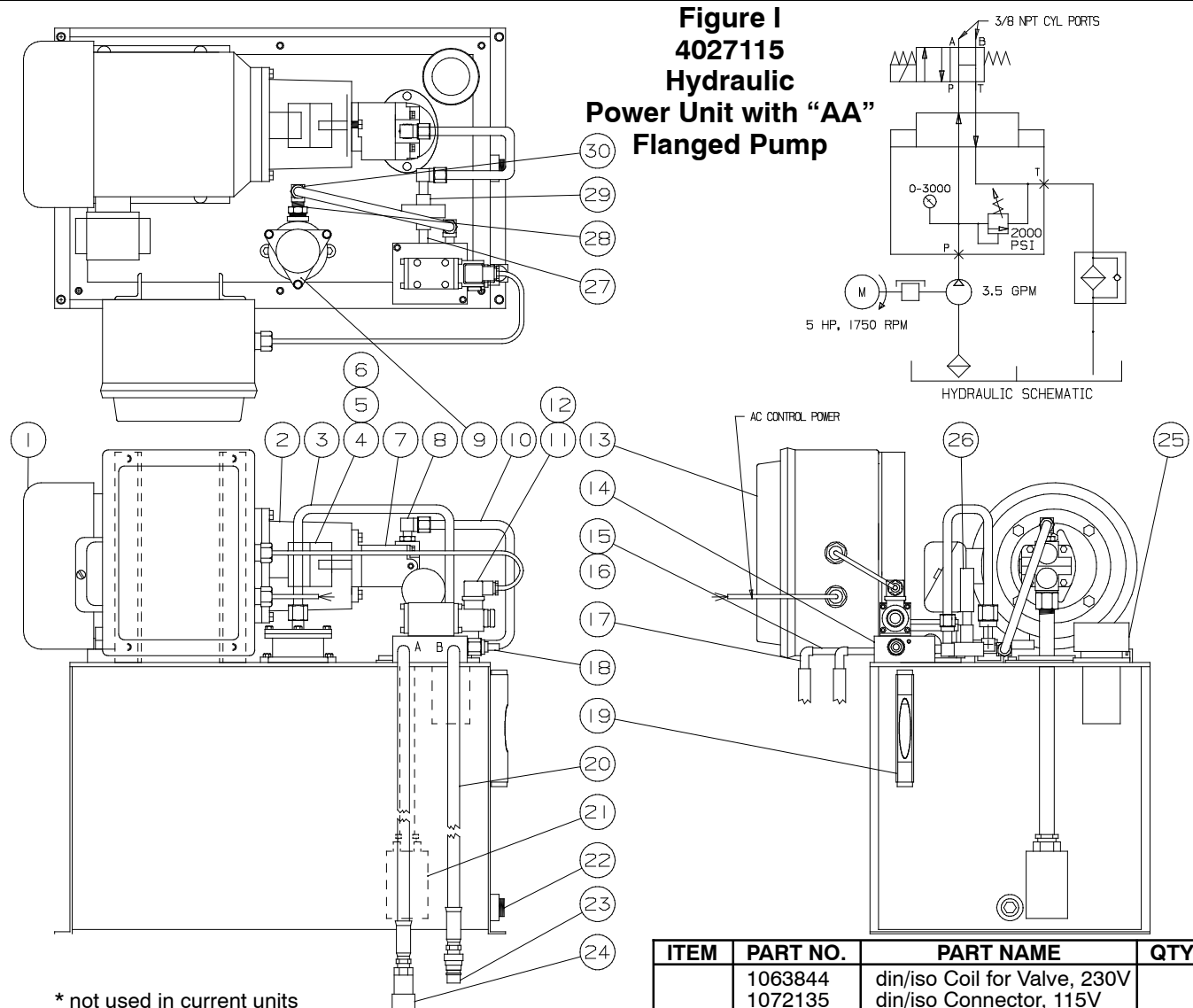

Figure H
Hydraulic Power Unit with "A"
Flanged Pump
4027271



ITEM	PART NO.	PART NAME	QTY
1	pg 11 or 12	Control Box Assembly	1
2	1008193	Elec. Mtr., 460/230V-60Hz	1
	1008197	Elec. Mtr., 440/400/230V,50Hz	
	1008196	Electric Motor, 575V-60Hz	
3	1071429	Return Tubing Assembly	1
4	1061733	Tubing Assy, Filter to Sub plate	1
5	1042361	Mounting Bracket	1
6	1011324	Coupling Half, Motor	1
7	1011326	Coupling, Spider Center	1
8	1011325	Coupling Half, Pump	1
9	1071431	Tubing Assy, Pump to Filter	1
10	3034031	High Pressure Filter Assy	1
	1034105	High Pressure Filter Element	
11	3008650	Hydraulic Gear Pump	1
12	1050515	Adapter Elbow	1
13	1025008	Hydraulic Pressure Gage	1
14	1034013	Oil Breather Filler Cap	1
15	1034064	Triangular Filter Assembly	1
	1034062	Filter Element only	

ITEM	PART NO.	PART NAME	QTY
16	1022043	Dir. Control Valve, 115V	1
	1022172	Dir. Control Valve, 230V	
	1063843	dir/iso Coil for Valve, 115V	
	1063844	dir/iso Coil for Valve, 230V	
17	1072135	dir/iso Connector, 115V	
	1072136	dir/iso Connector, 230V	
18	1055376	Socket Head Cap Screw	4
19	1022120	Sub-Plate with item 20	1
20	1022119	Cartridge Relief Valve	1
21	1050462	Hex Nipple (4 inch)	1
22	1050126	Pipe Elbow	2
23	1050090	Hex Nipple (2 inch)	1
24	1025045	Oil Level Gage	1
25	1034007	Suction Strainer	1
26	1054166	Drain Plug with Magnet	1
27	1059003	Hydraulic Hose Assy, 16 ft	2
28	1011086	Quick Connect Plug	1
29	1011087	Quick Connect Socket	1
	1017085	Electrical Danger Label	1



* not used in current units

ITEM	PART NO.	PART NAME	QTY
1	1008193	Elec. Mtr., 460/230V-60Hz	1
	1008197	Elec. Mtr., 400/230V-50Hz	
2	1042361	Mounting Bracket	1
3	1061734	Return Tubing Assembly	1
4	1011324	Coupling Half, Motor	1
5	1011326	Coupling, Spider Center	1
6	1011325	Coupling Half, Pump	1
7	3008113	Hydraulic Gear Pump	1
8	1050515	Adapter Elbow	1
9	1034064	Triangular Filter Assembly	1
10	1034062	Filter Element only	1
	1034052*	Square Filter Assembly	
	1034048*	Filter Element only	
	1061733	Supply Tubing Assembly	
	1022043	Dir. Control Valve, 115V	
11	1022172	Dir. Control Valve, 230V	1
	1063072*	Coil only for Valve, 115V	
	1063373*	Coil only for Valve, 230V	
	1063843	din/iso Coil for Valve, 115V	

ITEM	PART NO.	PART NAME	QTY
	1063844	din/iso Coil for Valve, 230V	
	1072135	din/iso Connector, 115V	
	1072136	din/iso Connector, 230V	
12	1055376	Socket Head Cap Screw	4
13	pg 10 or 11	Control Box Assembly	1
14	1022120	Sub-Plate with item 18	1
15	1050462	Hex Nipple (4 inch)	1
16	1050090	Hex Nipple (2 inch)	1
17	1050126	Pipe Elbow	2
18	1022119	Cartridge Relief Valve	1
19	1025045	Oil Level Gage	1
20	1059003	Hyd. Hose Assembly, 16 ft	2
21	1034007	Suction Strainer	1
22	1054166	Drain Plug with Magnet	1
23	1011086	Quick Connect Plug	1
24	1011087	Quick Connect Socket	1
25	1034013	Oil Breather Filler Cap	1
26	1025008	Hydraulic Pressure Gage	1
27	1050508	Hex Nipple, 1.5 inch	1
28	1050753	Reducer Bushing	1
29	1050127	Pipe Tee	1
30	1050668	Male Elbow	3
	1017085	Electrical Danger Label	1

Figure J
Control Box Assembly

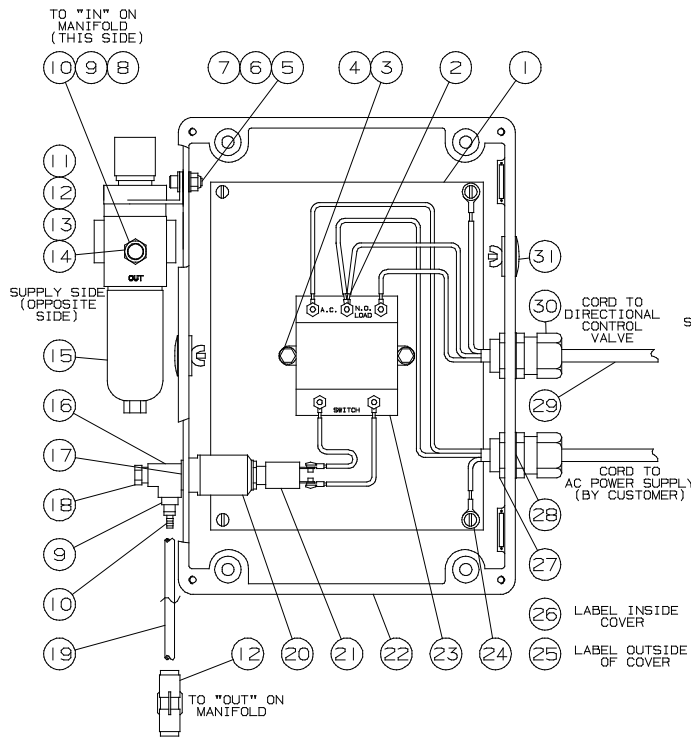

Single Trigger Tools

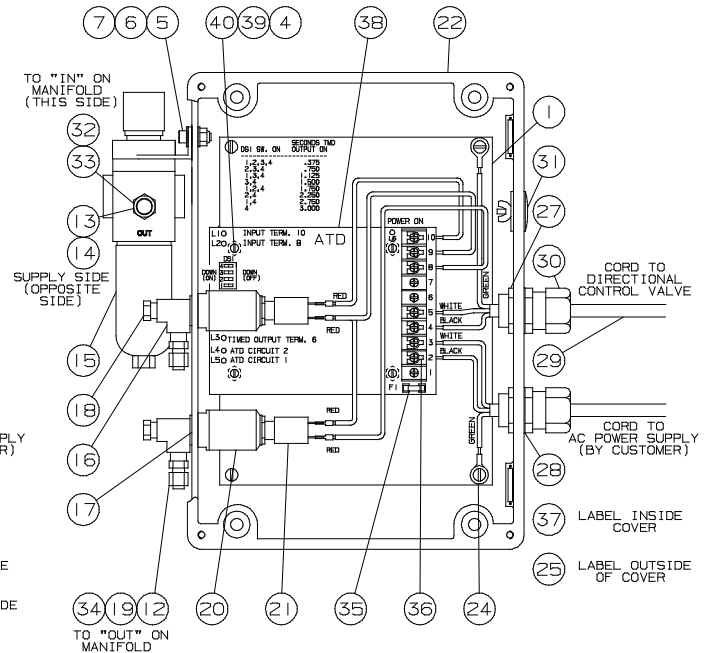

Dual Trigger Tools

ITEM	PART NO.	PART NAME	QTY
1	1032266	Mounting Plate	1
2	1063083	Wire Ring Terminal	8
3	1055477	Hex Head Screw	2
4	1004244	Internal Tooth Lock Washer	2
5	1055398	Socket Head Cap Screw	2
6	1004206	Washer	4
7	1007355	Hex Lock Nut	2
8	1051062	Reducer Bushing, Pipe	1
9	1050300	Square Head Plug	2
10	1051082	Tube Connector	2
11	1061458	Blue Tubing, 16 feet	1
12	1051119	Tube to Tube Connector	2
13	1050027	Street Elbow	1
14	1051001	Quick Connect Plug	1
15	1034014	Air Filter/Regulator	1
16	1051063	Street Tee	1
17	1004154	Washer	1
18	1051069	Hex Head Bleed Fitting	1
19	1061459	Yellow Tubing, 16 feet	1
20	1051065	Actuator	1
21	1005059	Push Button Switch	1
22	1016347	Control Box Enclosure	1
23	1063011	Electrical Relay	1
24	1063079	Wire Ring Terminal	2
25	1017085	Electrical Danger Label	1

ITEM	PART NO.	PART NAME	QTY
26	1017113	Wiring Diagram Label, 115V	1
	1017160	Wiring Diagram Label, 230V	
27	1007278	Locking Nut	2
28	1004211	Sealing Washer	2
29	1001295	Electric Cord, 4 feet	1
30	1011240	Strain Relief Connector	2
31	1063238	Electrical Enclosure Plug	2
32	1051211	Tube to Pipe Connector	1
33	1061347	Black Tubing, 20 feet	1
34	1051124	Tube to Pipe Connector	2
35	1072091	Fuse	1
36	1063502	Wire Fork Terminal	13
37	1017320	Wiring Diagram Label, 115V	1
	1017321	Wiring Diagram Label, 230V	
38	1072071	ATD Circuit Board, 115V	
	1072072	ATD Circuit Board, 230V	
39	1029445	Hex Spacer	4
40	1073072	Plastic Slotted Head Screw	4
		Single Trigger:	
	3016192	Control Box Assy, 115V	
	3016219	Control Box Assy, 230V	
		Dual Trigger:	
	3063282	Control Box Assy, 115V	
	3063362	Control Box Assy, 230V	

Figure 1
Hose Connection Diagram
Single Trigger

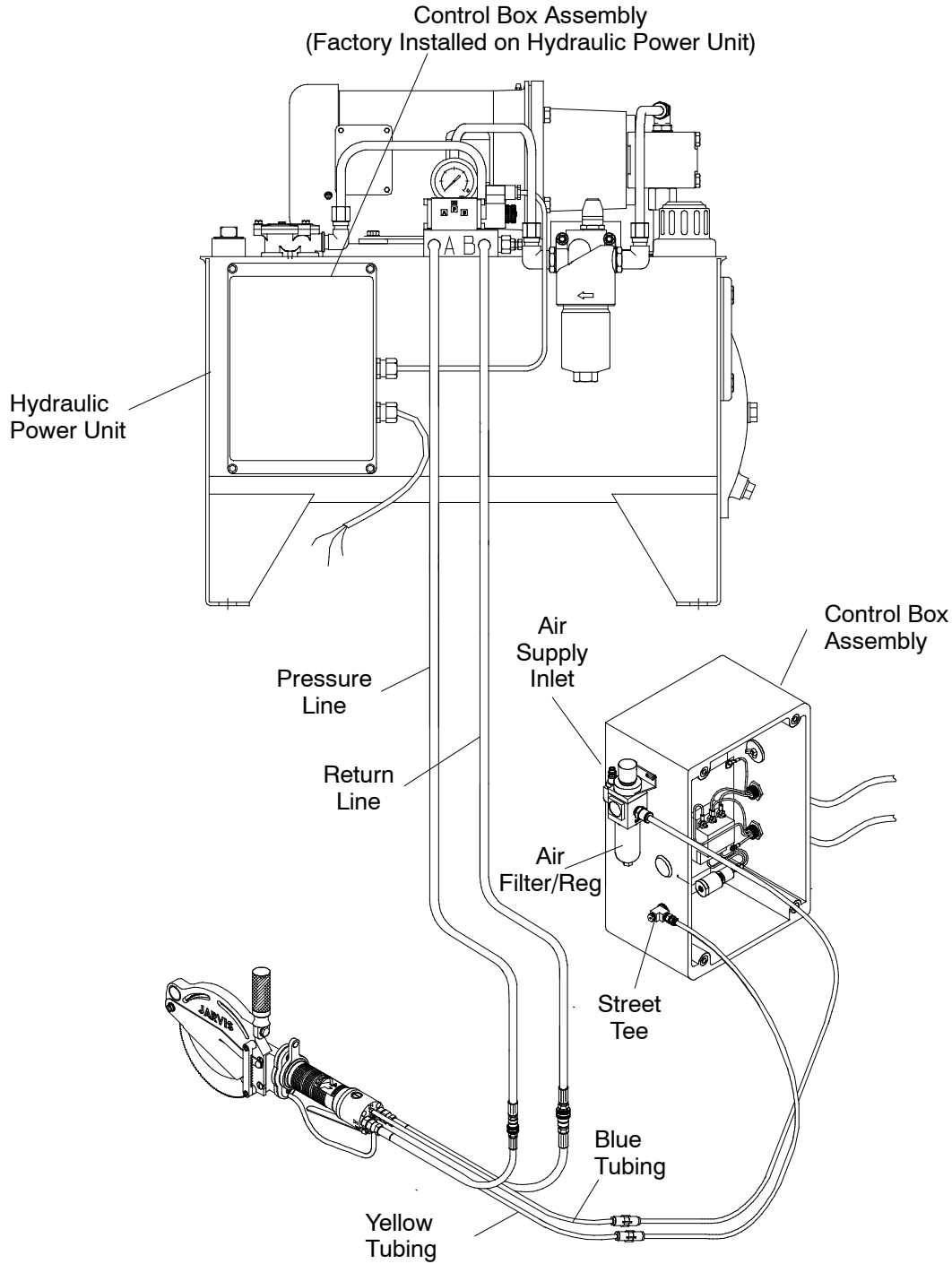

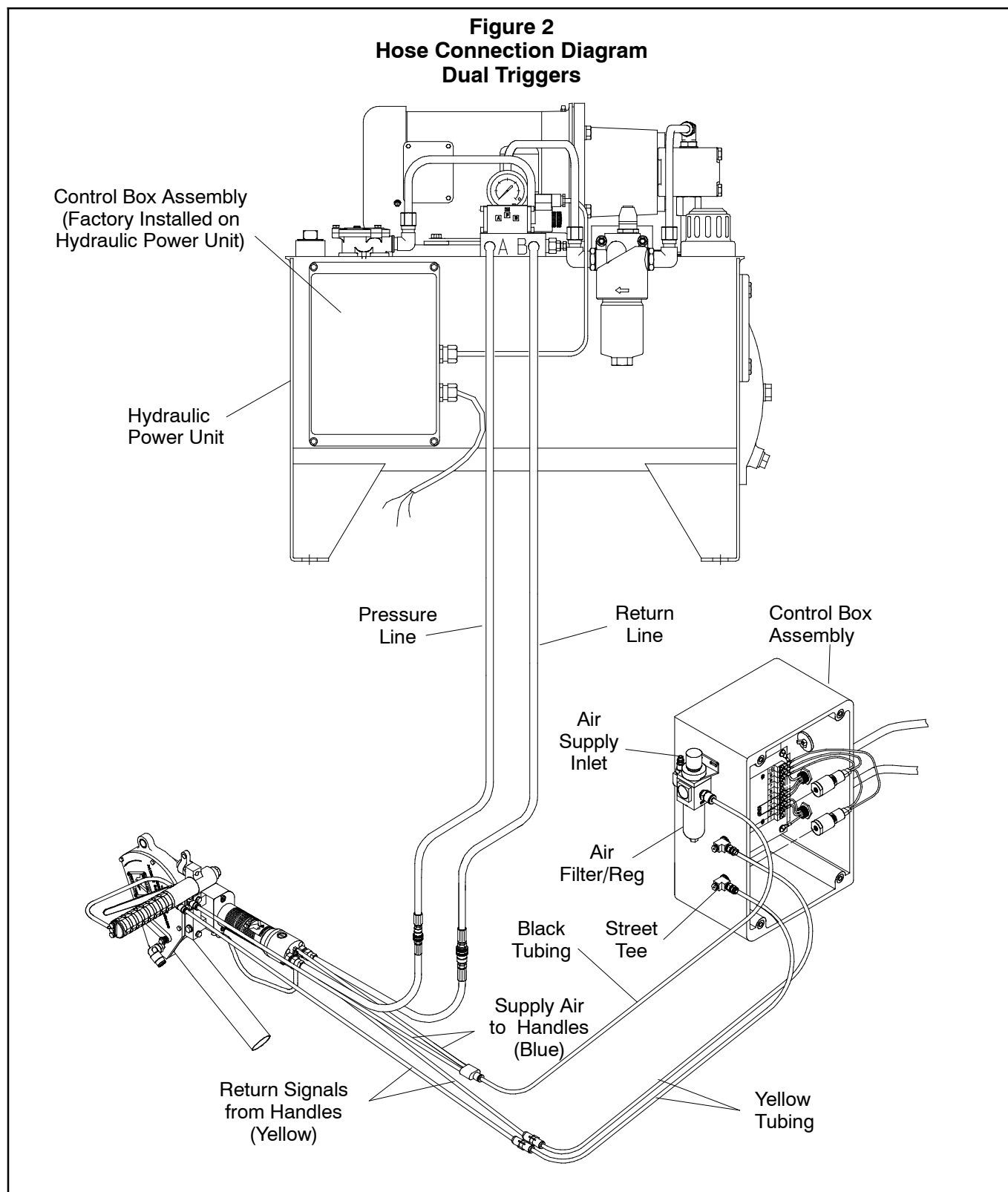

SPECIFICATIONS

All Models

Motor Power	2.5 hp	1865 W
Blade Speed at 3.5 gal/min	2725 rpm	
Vibration	less than (<) 100 dB	< 0.1 m/sec ²
Noise (one meter from tool)	87 dB	

Model SHC 140, 165 and 205

Control Handle	Single trigger / Pneumatic	
Blade Diameter	8.1 in	205 mm
	6.5 in	165 mm
	5.5 in	140 mm
Cutting Depth	2.8 in	71.0 mm
	2.0 in	50.8 mm
	1.5 in	38.1 mm
Overall Length	16.5 in	419 mm
Weight	7 lbs	3.2 kg

Model SHC 165G and 165GT

Control Handle	Dual Anti-Tie Down / Pneumatic		
Cutter Head Width	Pork	0.51 in	13 mm
	Beef	0.63 in	16 mm
Cutting Depth	Pork	0.81 in	20.6 mm
	Beef	0.88 in	22.4 mm
Overall Length	15 in	381 mm	
Weight	8.6 lbs	3.9 kg	

Hydraulic Power Unit

Motor Power	5 hp	3728 W
Operating Voltage	all voltages and 50 Hz. available	
Hose Length	16 ft	5 m
Oil Capacity	20 gal	76 L
Oil Visc. at 100° F/40° C	200 SUS	46 ISO
Oil Flow Rate	3.5 gal/min	13.2 L/min
Overall Dimensions (l x w x h)	28 x 23 x 28 in	
	711 x 584 x 711 mm	
Weight (without oil)	225 lbs	102 kg

INSTALLATION INSTRUCTIONS

ALWAYS DISCONNECT THE POWER SUPPLY IN ACCORDANCE WITH OSHA'S LOCKOUT/TAGOUT PROCEDURES (29 CFR 1910.147) BEFORE PERFORMING ANY REPAIRS OR MAINTENANCE.

ALL WIRING MUST BE DONE IN ACCORDANCE WITH NATIONAL, STATE AND LOCAL ELECTRICAL CODES.

Refer to Figure 1 or 2 on page 12 or 13 as a guide for connecting the air and hydraulic hoses.

- 1 Install the SHC saw above the work station from a balancer. **Jarvis** part number 4042033 or 4042044 is available.
 - 1.1 The SHC saw should have enough travel to allow the operator to reach the entire work area.
- 2 Install the hydraulic power unit overhead or on the floor behind the work station.
 - 2.1 Avoid excessive height and long pipe runs.
- 3 Wire the power unit. Refer to the wiring diagram label inside the control box cover (item 37, Figure J, page 11) for the correct operating voltage and frequency.
- 4 Equip the power unit with a master pilot light switch at the operators station. ***This will facilitate shut-down in case of an equipment failure.***
- 5 Fill the oil reservoir with a USDA approved premium grade hydraulic fluid (viscosity: 200 SUS at 100° F / 46 ISO at 40° C).
- 6 Make all necessary air hose connections.

Single Trigger Tools: Refer to Figure J, page 11.

- 6.1 For the air supply line: use tube to tube connector (item 12) to connect blue plastic tubing (item 11) from air filter / regulator (item 15) to blue plastic tubing (item 189, Figure G, page 8) from the port marked "IN" on hydraulic manifold (item 187, Figure G, page 8 or item 65, Figure B, page 5).
- 6.2 For the air return line: use tube to tube connector (item 12) to connect yellow plastic tubing (item 19) from tube connector (item 10) to yellow plastic tubing (item 123, Figure F, page 7) from the port marked "OUT" on hydraulic manifold (item 187, Figure G, page 8 or item 65, Figure B, page 5).

Dual Trigger Tools: Refer to Figure J, page 11.

- 6.3 For the air supply line: use “Y” fitting (item 124, Figure F, page 7) to connect black plastic tubing (item 33) from air filter / regulator (item 15) to blue plastic tubing (item 122, Figure F, page 7) from the port marked “IN” on hydraulic manifold (item 187, Figure G, page 8), and to blue plastic tubing (item 125, Figure F, page 7) from elbow fitting (item 127, Figure F, page 7) closest to gear head (item 99, Figure D, page 6).
- 6.4 For the air return line: use tube to tube connectors (item 34) to connect yellow plastic tubing (item 19) from tube to pipe connectors (item 34) to yellow plastic tubing (item 126, Figure F, page 7) from the port marked “OUT” on hydraulic manifold (item 187, Figure G, page 8), and to yellow plastic tubing, (item 123, Figure F, page 7) from elbow fitting (item 127, Figure F, page 7) furthest from gear head (item 99, Figure D, page 6).

For Single and Dual Trigger Tools: Refer to Figure H, page 9 unless noted otherwise.

- 7 Make all necessary hydraulic hose connections.
 - 7.1 Connect the quick connect socket (item 29) of the supply line marked “A” on the hydraulic power unit to the quick connect plug (item 190, Figure G, page 8) connected to the hydraulic manifold port marked “IN.”
 - 7.2 Connect the quick connect plug (item 28) of the return line marked “B” on the hydraulic power unit to the quick connect socket (item 180, Figure G, page 8) connected to the hydraulic manifold port marked “OUT.”
- 8 Note: There are no adjustments to be made at the hydraulic power unit for blade speed or hydraulic pressure. The blade speed is a result of using the full output of the pump and cannot be increased. The pump is set to a maximum relief pressure of 2000 psi. During operation, the pressure gage (item 13, Figure H, page 9) will only show the pressure required to make the cut. The pressure gage should read approximately 300 psi with the saw running under no load.

OPERATION INSTRUCTIONS

ALWAYS DISCONNECT ALL HYDRAULIC AND AIR HOSES AND SHUT OFF THE POWER SUPPLY IN

ACCORDANCE WITH OSHA’S LOCKOUT/TAGOUT PROCEDURES (29 CFR 1910.147) BEFORE PERFORMING ANY REPAIRS OR MAINTENANCE.

- 1 Turn on the power.
- 2 *Prior to use or daily*, perform the following tests:

For Single Trigger Tools:

- 2.1 Make sure that the trigger lever (item 188, Figure G, page 8) is working correctly. Depress the trigger and the tool should start. Release the trigger and the tool should stop. *If the tool malfunctions, remove it from service and report the problem to your supervisor immediately.*
Always use two hands when starting and stopping the tool. Continue holding the tool with two hands until the saw blade comes to a complete stop.

For Dual Trigger Tools:

- 2.2 Make sure that the dual anti-tie down control triggers on the side and rear handles are working correctly. **Depress each trigger separately** and the tool should not start. **Depress** one trigger, then pause one second and depress the other trigger and the tool should not start. Repeat this procedure reversing the triggers. **Depress both** triggers simultaneously (within one half second of each other) and the tool should start. With the tool running, **release one** trigger and the tool should stop. Continue holding the depressed trigger and then depress the other trigger. The tool should not start. **Repeat** this procedure holding the other trigger. *If the tool malfunctions, remove it from service and report the problem to your supervisor immediately.*
Always use two hands when starting and stopping the tool. Continue holding the tool with two hands until the saw blade comes to a complete stop.
- 2.3 Make sure the SHC saw moves freely on the balancer.
- 3 Making the cut.
 - 3.1 Position the SHC saw.
 - 3.2 Depress the trigger fully to start the motor and make the cut.
Always use two hands when starting the tool and while making the cut.

- 3.3 When the desired length of cut is reached, release the trigger. This will stop the blade from rotating.

Continue holding the tool with two hands until the saw blade comes to a complete stop.

- 3.4 Withdraw the saw blade from the carcass.

Note: Avoid banging the blade into bone, as this could damage the saw due to the cutting power available. All cuts should be made in a firm, steady motion with the carcass supported to prevent it from moving with the pressure of the blade.

MAINTENANCE INSTRUCTIONS

ALWAYS DISCONNECT ALL HYDRAULIC AND AIR HOSES AND SHUT OFF THE POWER SUPPLY IN ACCORDANCE WITH OSHA'S LOCKOUT/TAGOUT PROCEDURES (29 CFR 1910.147) BEFORE PERFORMING ANY REPAIRS OR MAINTENANCE.

Refer to Figures A to G on pages 4-8 for referenced items.

1 DAILY:

Note: The hydraulic and air hoses must be connected and the power turned on to perform the above maintenance check only.

For Single Trigger Tools:

- 1.1 Make sure that the trigger lever (item 188) is working correctly. Depress the trigger and the tool should start. Release the trigger and the tool should stop. *If the tool malfunctions, repair or remove it from service immediately.*

For Dual Trigger Tools:

- 1.2 Make sure that the dual anti-tie down control triggers on the side and rear handles are working correctly. **Depress each trigger separately** and the tool should not start. **Depress** one trigger, then pause one second and depress the other trigger and the tool should not start. Repeat this procedure reversing the triggers. **Depress both** triggers simultaneously (within one half second of each other) and the tool should start. With the tool running, **release one** trigger and the tool should stop. Continue holding the depressed trigger and then depress the other trigger. The

tool should not start. **Repeat** this procedure holding the other trigger. *If the tool malfunctions, remove it from service and report the problem to your supervisor immediately.*

Always use two hands when starting and stopping the tool. Continue holding the tool with two hands until the saw blade comes to a complete stop.

- 1.3 Four (4) times per day, add **Jarvis 1315 White Grease** to the grease fitting (item 20 or 96) in the gear housing (item 21, 50 or 99).
- 1.4 Check the level of the hydraulic fluid in the power unit.
- 1.5 Inspect all hoses for leaks, cuts and abrasions and replace if necessary.
- 1.6 Check all fittings for leaks and tighten or replace, as necessary.

2 WEEKLY:

- 2.1 Check the condition of the fluid in the hydraulic power unit. Replace the fluid if it appears dirty or smells burnt. Always replace the filters (items 10 and 15, Figure H, page 9) when changing the fluid.

3 BLADE REMOVAL:

SHC-140, 165, 165B and 205 Models

- 3.1 Loosen or remove (SHC-165B) flat head screws (item 44 or 55) and pivot the blade guard and gage assembly (item 9, 37 or 48) up and away from the blade.
- 3.2 Remove the blade retaining screw (item 10) and blade retaining washer (item 11) and remove blade (item 12 or 49).
 - 3.2.1 Place blade locking pin (item 40) through the hole in the blade to prevent it from rotating.
- 3.3 Inspect all parts for wear and replace, as necessary.
 - 3.3.1 Sharpen or replace the blade, as necessary.

SHC-165G Model

- 3.4 Remove hex head screws (item 79) and separate cover assembly (items 75-81, 103 and 104) from blade guard (item 88).
- 3.5 Remove the blade retaining screw (item 82) using adjustable spanner wrench (8039093).

- 3.6 Remove blade insert holder (item 83) with blade inserts (item 101) and slinger (item 84) still attached.
- 3.7 Inspect all parts for wear and replace, as necessary.
 - 3.7.1 Remove and replace the blade inserts (item 101), as necessary.

SHC-165GT Model

- 3.8 Remove hex head screws (item 79) and separate cover assembly (items 75-80, 103-106) from blade guard (item 88).
- 3.9 Remove the blade retaining screw (item 107), lock washer (item 108), and blade retaining washer (item 109). Remove blades (item 110).
 - 3.9.1 Place blade locking pin (item 40) through the hole in the blades to prevent them from rotating.

4 BLADE INSTALLATION:

- 4.1 Reverse steps and procedures outlined in section 3. Refer to Figure 3 below as a guide for installing blade.
 - 4.1.1 To ensure proper fit and safe operation, the slinger (item 13 or 84) and saw blade (item 12, 49 or 110) or blade insert holder (item 83) must fit securely on the lip of crown gear (item 18, 91 or 112).
 - 4.1.2 The teeth or blade inserts at the bottom of the blade or blade insert holder should point toward the operator and rotate counter-clockwise.

5 BLADE SCRAPER REMOVAL: (SHC-165G and SHC-165GT)

- 5.1 Remove hex head screws (item 75), adjustable studs (item 76) and blade scraper (item 77 or 105).
- 5.2 Inspect all parts for wear and replace, as necessary.

6 BLADE SCRAPER ASSEMBLY: (SHC-165G)

- 6.1 Reverse step 5.1.
- 6.2 With hex screws (item 75) only finger tight, rotate adjustable studs (item 76) until blade scraper (item 105) just contacts the blade inserts (item 101) on the blade insert holder (item 83). Back off the adjustable studs (item 76) $1/16$ th of a turn. Tighten hex screws (item 75).

7 GEAR HOUSING DISASSEMBLY:

- 7.1 Remove blade and blade guard as outlined in section 3.
- 7.2 Remove the two screws (item 32) and separate the gear head assembly from the hydraulic motor assembly. Set motor assembly aside.
- 7.3 Remove the slinger (item 13 or 84) from the lip of gear housing cover (item 16) or blade guard (item 88).
- 7.4 Remove the three screws (item 15 or 87) and remove the gear housing cover (item 16) or blade guard (item 88).
- 7.5 Lightly tap the gear housing (item 21, 50 or 99) with a nylon mallet in the vicinity of the guard mounting flange to dislodge the crown gear and bearings (items 17-19 or 90-95).
- 7.6 Disassemble the crown gear.
 - 7.6.1 Press the ball bearing (item 17 or 90) from the crown gear (item 18 or 91).
 - 7.6.2 Turn crown gear around and press the ball bearing (item 19 or 94) from shaft of crown gear.
- 7.7 Remove the internal retaining ring (item 27) from the gear housing (item 21, 50 or 99).
- 7.8 Lightly tap the gear housing (item 21, 50 or 99) with a nylon mallet in the vicinity of the guard mounting flange to dislodge the pinion gear assembly (items 23-26).

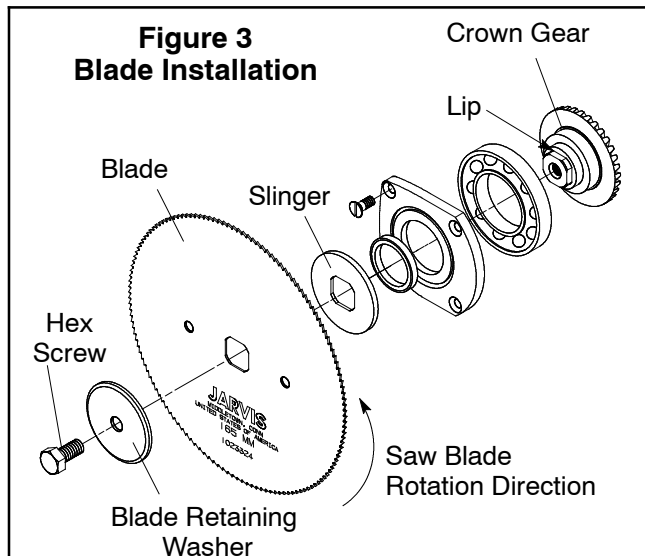

- 7.9 Disassemble the pinion gear.
 - 7.9.1 Press the ball bearing (item 26) from the coupling (item 25).
 - 7.9.2 Press the coupling (item 25) from the pinion gear (item 23).
- 7.10 Remove bearing race (item 24), if necessary.
- 7.11 Inspect all parts for wear and replace as necessary.

- 8.1.2 When installing internal retaining ring (item 27), make sure that the beveled edge faces away from gear housing (item 21, 50 or 99). See Figure 5 below.

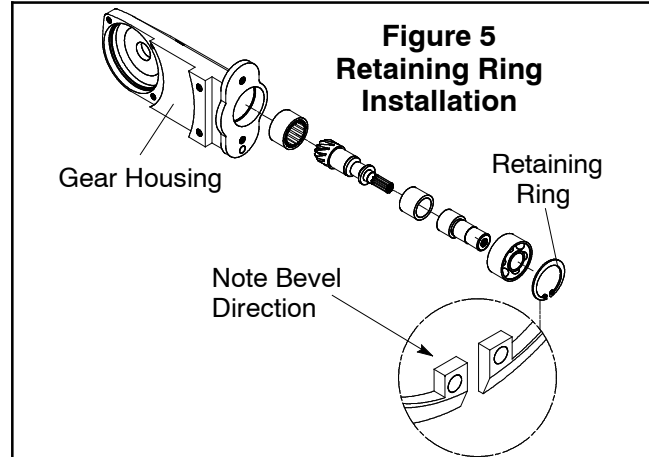
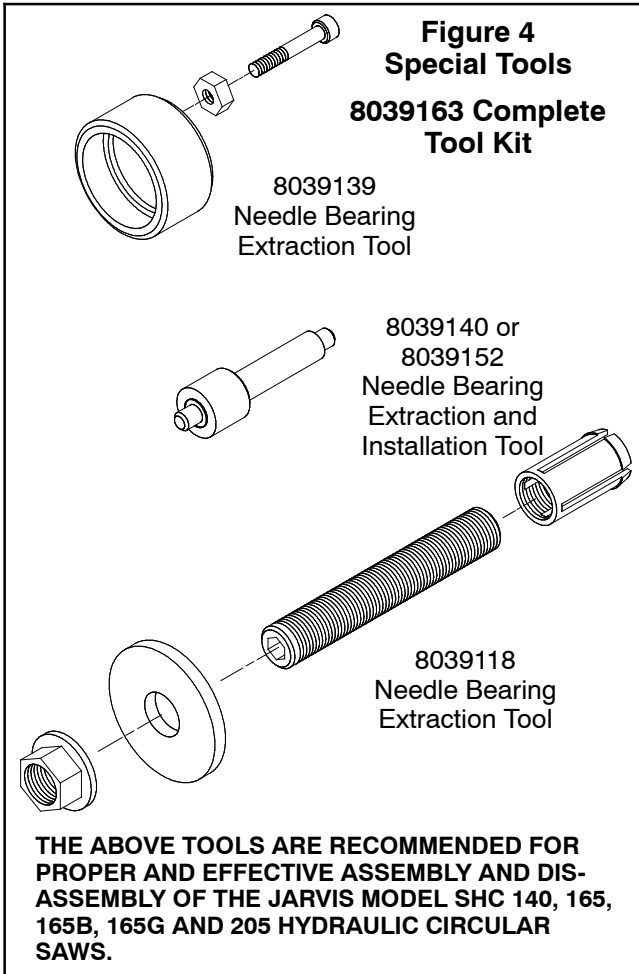

8 GEAR HOUSING ASSEMBLY:

- 8.1 Reverse procedure outlined in section 7. See special notes below.
 - 8.1.1 Jarvis assembly tool 8039152 is available for the installation of needle bearing (item 22). See Figure 4. Always press on the lip that has the manufacturer's markings. Note: Pressing the unmarked (and unhardened) lip will deform and damage the bearing.

- 9 Remember to install wave spring (item 95) in gear head (item 99) before crown gear assembly (items 90-94).
- 10 DRIVE SHAFT SEAL REPLACEMENT - Old Style:

Note: It is not necessary to disassemble the hydraulic motor to replace the old style drive shaft seal. All components of shaft seal cartridge (items 142-147) must be replaced with hydraulic motor seal kit, 3035058.

- 10.1 Separate the gear housing (item 21, 50 or 99) and motor assembly as outlined in section 7, steps 7.1-7.3.
- 10.2 Remove the two screws (item 32) and remove motor adapter plate (item 29, 52 or 121).
- 10.3 Remove the internal retaining ring (item 141) and use the lip on the seal housing (item 143) to gently lift the seal cartridge (item 142-147) from the motor.
- 10.4 Inspect the drive shaft (item 148) for wear or galling. If the shaft is only polished, proceed to step 10.5. If shaft needs replacing, refer to sections 11 and 12.
- 10.5 Remove the internal retaining ring (item 147).
- 10.6 Lubricate the new seal (item 144) with Jarvis 1315 White Grease and install it in new seal gland (item 146).

- 10.7 Replace the o-rings (items 142 and 145) with new ones from seal kit and apply a liberal coat of **Jarvis 1315 White Grease** to the o-rings and drive shaft.
- 10.8 Install internal retaining ring (item 147).
- 10.9 Install new seal cartridge (items 142-147) and internal retaining ring (item 141) into the motor.
- 10.10 Reassemble the motor to the gear housing, reversing procedures outlined in section 7, steps 7.1-7.3.

11 DRIVE SHAFT SEAL REPLACEMENT - New Style:

Note: Hydraulic repair kit 3035093 should be available before disassembling motor.

- 11.1 Disassemble motor as described in section 12, steps 12.1-12.8.
- 11.2 Remove bearing retaining ring (item 178).
- 11.3 Slide drive shaft (item 175) with ball bearings (items 176) from motor front housing (item 169).
- 11.4 Remove external retaining ring (item 177) and ball bearings (item 176) from drive shaft (item 175). Inspect and replace if necessary.
- 11.5 Remove internal retaining ring (item 174).
- 11.6 Remove seal housing (item 172) with o-ring (item 173), seal (item 171) and seal retaining washer (item 170).
- 11.7 Discard items 152, 171-174 and 178. Replacements are included in repair kit 3035093.
- 11.8 Reassemble o-ring (item 173) onto seal housing (item 172).
- 11.9 Assemble internal retaining ring (item 174), seal housing (item 172) with o-ring (item 173), seal (item 171) and seal retaining washer (item 170) onto drive shaft (item 175).
- 11.10 Apply a liberal coat of **Jarvis 1315 White Grease** to all seals, o-rings and drive shaft.
- 11.11 Gently insert drive shaft and components assembled above into motor front housing (item 169).
- 11.12 Insert external retaining ring (item 174) into groove in motor front housing (item 169).
- 11.13 Reinstall ball bearings (items 176), external retaining ring (item 177) and bearing retaining ring (item 178).
- 11.14 Reassemble the motor to the gear housing, reversing procedures outlined in section 7, steps 7.1-7.3.

12 HYDRAULIC MOTOR DISASSEMBLY:

Note: Cleanliness of the maintenance work area should be maintained whenever performing any work on the tool. Due to the exacting nature of the tolerances in a hydraulic motor, extra vigilance must be observed. Even a small amount of foreign matter can cause immediate failure, or seriously degrade the motor's performance and shorten its life. Inspect all parts for dirt or dust prior to installation and keep them covered with a lint-free cloth when not working on them.

Note: Never place the motor or any of its components in a vise. Deformation will occur.

Old and New Style Motors

- 12.1 Separate the gear housing (item 21, 50 or 99) and motor assembly as outlined in section 7, steps 7.1-7.3.
- 12.2 Remove the two screws (item 32) and remove the motor adapter plate (item 29, 52 or 121).
- 12.3 Remove the four screws (item 67 or 184) and remove the hydraulic manifold assembly (items 59-65 or 71-73, 134 and 185-188).
- 12.4 Remove the four screws (item 179) and separate the manifold plate (item 163) from the motor.
- 12.5 Remove the four screws (item 162).
- 12.6 Gently pull the rear motor housing (item 161 or 164) from the motor.
- 12.7 Gently remove the motor center plate (item 157). *Be careful not to scratch the bores of the center plate on the hydraulic gear teeth.*
- 12.8 Remove the two gears (item 156 or 166), the key (item 154 or 168) and idler shaft (item 155 or 167).

Old Style Motor

- 12.9 Remove and disassemble the seal cartridge as outlined in section 10, step 10.3-10.5.
- 12.10 Remove the drive shaft and bearing assembly (items 148-150). Remove the retaining ring (item 150) from the drive shaft (item 148) and press the drive shaft from the bearing (item 149).

New Style Motor

12.11 Disassemble motor as described in section 11, steps 11.2 - 11.7.

Old and New Style Motors

Note: The motor O-rings (item 152) will acquire a permanent set in their cross section after they have been in service. This will reduce their effectiveness upon re-use. The motor o-rings should always be replaced whenever the motor is disassembled.

12.12 Remove the two o-rings (item 152) from their respective housings and discard.

12.13 Remove the needle bearings (item 153 or 165) from the front and rear motor housings (items 151 or 169 and 161 or 164). **Jarvis** tool 8039139 is available. *See Figure 6 below.*

12.13.1 Insert the 5 mm screw (1055993) and nut (1007243) through the bearing extraction tool and into the bearing extraction washer (item 159). Restrain the screw from rotating while turning the nut clockwise to remove the bearing from the bore. *See Figure 6 below.*

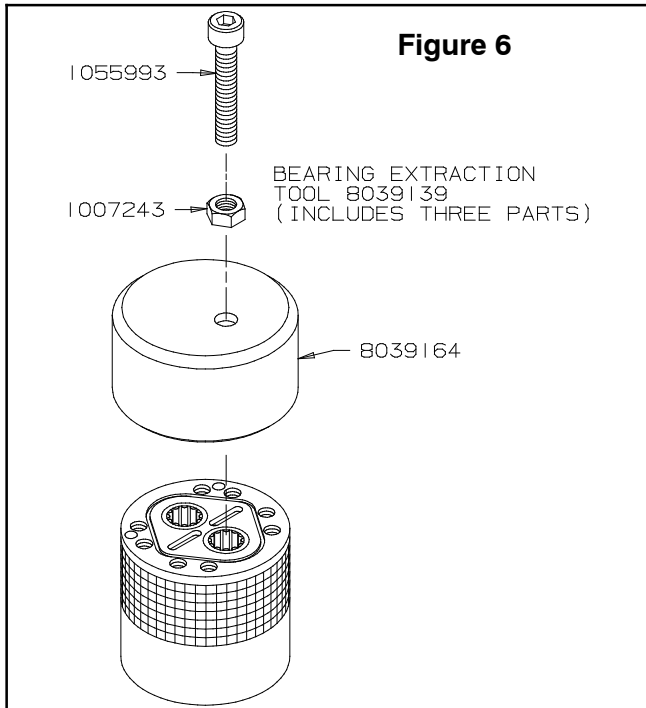

12.13.2 The needle bearing for drive shaft (item 148 or 175) can be pressed out through the gear head side of the front motor housing (item 151 or 169). **Jarvis** tool 8039140 is available. *See Figure 4 on page 18.*

12.14 Inspect all parts for wear and replace as necessary. Take special note of the condition of the bores in the motor center plate (item 157), the needle bearing journals on drive shaft (item 148 or 175) and idler shaft (item 155 or 167), and the square key (item 154 or 168).

12.15 Inspect the ground faces of the front and rear motor housings (items 151 or 169 and 161 or 164), center plate (item 157), manifold plate (item 163) and hydraulic manifold (item 65 or 187) for nicks or burrs. Small burrs may be removed by lightly polishing the surface on a flat stone. Larger defects or any defect that intrudes into an o-ring groove require the replacement of the damaged part.

13 HYDRAULIC MOTOR ASSEMBLY:

Note: Thoroughly clean all motor components prior to installation.

13.1 Reverse steps and procedures outlined in section 11. *See special notes below.*

13.1.1 **Jarvis** assembly tool 8039140 is available for the installation of needle bearings (item 153 or 165). *See Figure 4 on page 18.* Always press on the lip that has the manufacturer's markings. *Note: Pressing the unmarked (and unhardened) lip will deform and damage the bearing.*

13.1.2 Replace the motor o-rings (item 152) with new ones before re-assembling the motor.

13.1.3 Tighten screws (item 162 and 179) to 50 lbf-in (5.6 N-m).