

HGCU Series Hollow Grinders

*For consistent and precise blade thinning operations,
trust the proven HGCU series of grinders from PRIMEEdge*



COZZINIPRIMEEdge
CUTTING EDGES AND SHARPENING SOLUTIONS

Hollow Grinder

Models HG4CU and HG6CU

- Ideal for high-volume knife users.
- Available with Ø4" (102 mm) or Ø6" (152 mm) cup stones.
- Thins blades for edging up to 16" (406 mm) long.
- Recirculating liquid coolant system provides burn-free and dust-free operation.
- Unique cup wheel sharpening stone design assures consistent grind bevel widths.
- Integrated, pneumatically-controlled, stone dressing system maintains roundness of the cup stones for perfect, consistent, sharp edges.
- Built-in go/no-go gauge determines at a glance if the blade is thinned enough for edging and honing.
- CE approved.

JARVIS

Jarvis ANZ Pty Ltd.
6 Rosa Place
Richlands, QLD 4077

Phone: 617-3375-3444
Fax: 617-3375-3533
E-mail: sales@jarvisanz.com.au
www.jarvisanz.com.au

HGCU Series Hollow Grinders

For efficient, high-volume knife sharpening operations, **PRIME**edge HGCU Grinders are used to thin blades prior to edging and honing. 4" (102 mm) or 6" (152 mm) cup stones provide the unique advantage of maintaining the same stone bevel and diameter as the stones wear, thereby assuring a consistent grind bevel width. When combined with our Honer/Edger (HE7) as part of a centralized knife sharpening system, productivity increases and ergonomic problems decrease.

The ergonomic design of the Hollow Grinder provides operator comfort and safety. An adjustable, pivoting lamp can be oriented in different positions for excellent visibility while grinding blades. The sturdy stainless steel body with fiberglass cover provides long life and easy maintenance access.

For a consistent and precise blade thinning operation, trust the proven HGCU series of Grinders from **PRIME**edge.

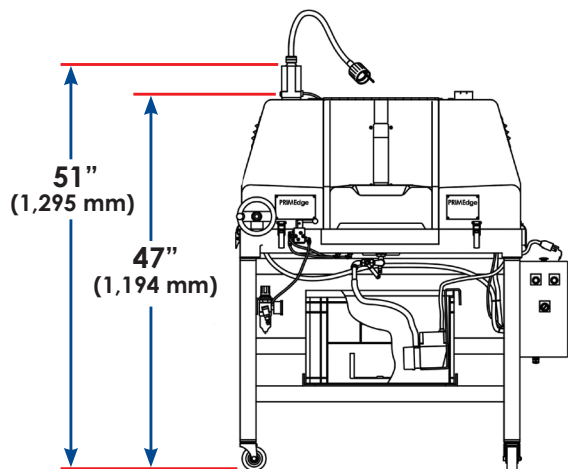
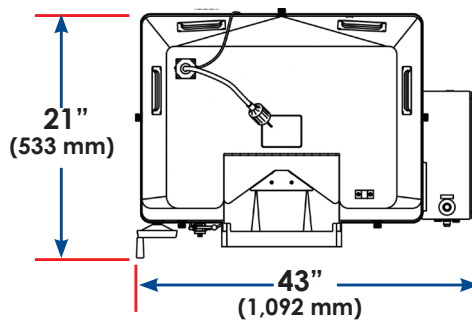

Hollow Grinders				
Model	Voltage	Phase	HP	kW
HG4CU	220V	1	.50 (x2)	.4 (x2)
	230/460 or 380V	3	.50 (x2)	.4 (x2)
HG6CU	220V	1	.75 (x2)	.6 (x2)
	230/460 or 380V	3	.75 (x2)	.6 (x2)

COZZINIPRIME**Edge**
CUTTING EDGES AND SHARPENING SOLUTIONS

JARVIS

Jarvis ANZ Pty Ltd.
6 Rosa Place
Richlands, QLD 4077

Phone: 617-3375-3444
Fax: 617-3375-3533
E-mail: sales@jarvisanz.com.au
www.jarvisanz.com.au